

Study the Effects of Renewable Resources on Electric Grid Frequency

Mohamed Abuella

ECGR8090 POWER QUALITY

Fall 2014

University of North Carolina at Charlotte

Presentation Outline

```
graph TD; A["Presentation  
Outline"] --- B["Frequency  
Deviation  
Causes"]; A --- C["Frequency  
Deviation  
Impacts"]; A --- D["Frequency  
Deviating  
Mitigations"];
```

**Frequency
Deviation
Causes**

**Frequency
Deviation
Impacts**

**Frequency
Deviating
Mitigations**

Frequency deviation causes

Renewables Generations (Wind and Solar) are Too Variable

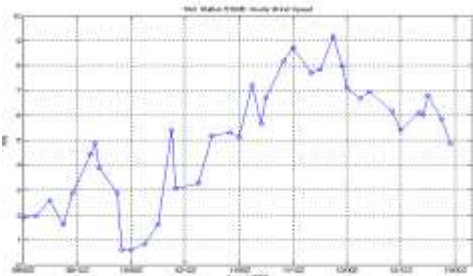

$$P_G = P_D + P_{loss}$$

$$\Delta P \rightarrow \Delta f$$

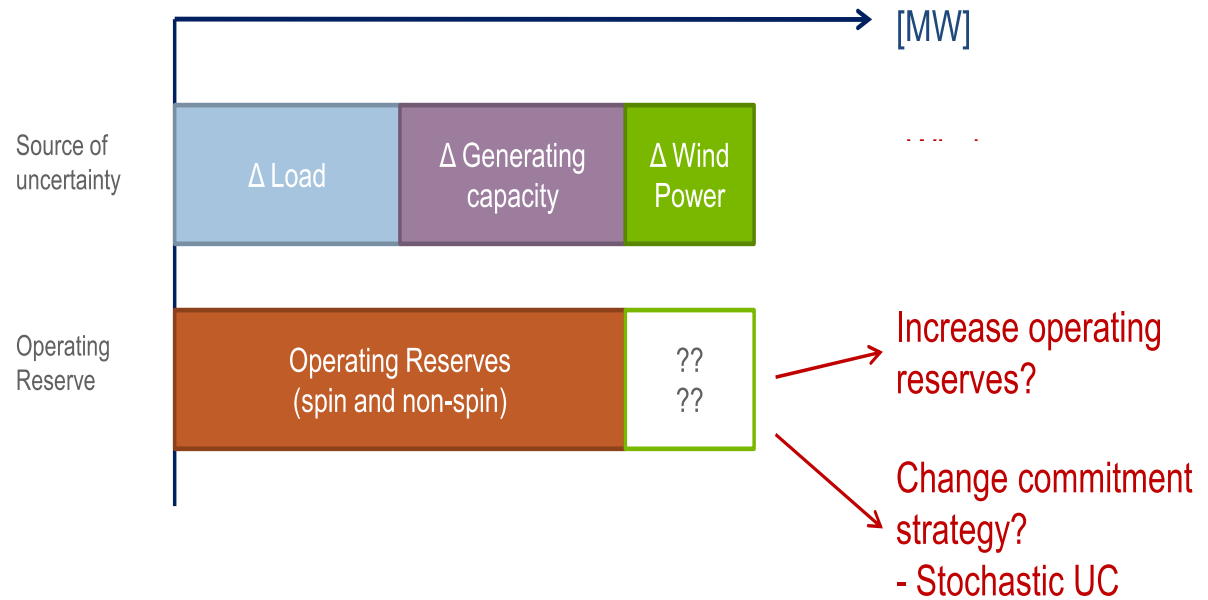
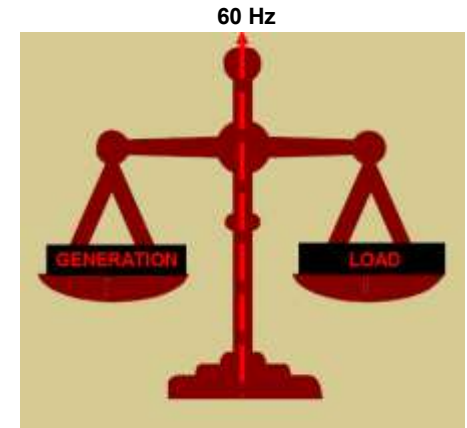

- *What are the impacts on the system?*
 - *Reliability (curtailment,..)*
 - *Efficiency (system cost, price..)*

Frequency deviation causes

Prime Mover Governor Automatic Generation Control (AGC)

$$P_G = P_D + P_{loss}$$

$$\Delta P \rightarrow \Delta f$$

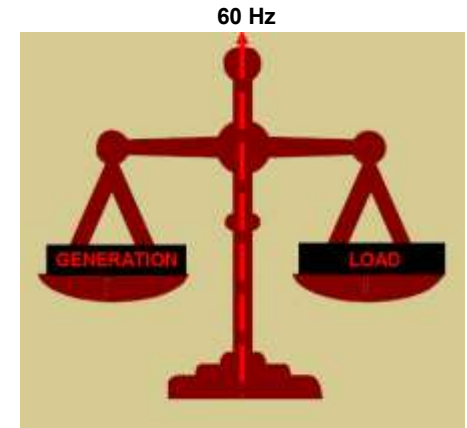

Area Control Error (ACE) → Minimize {ΔP, Δf}

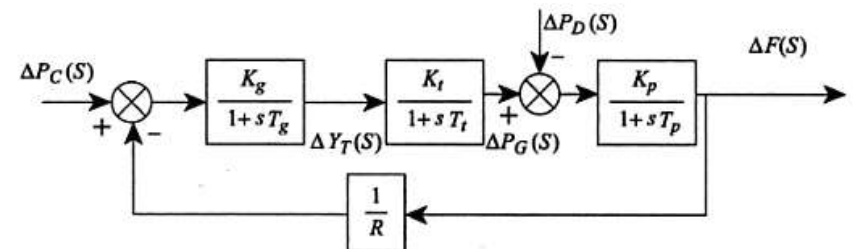
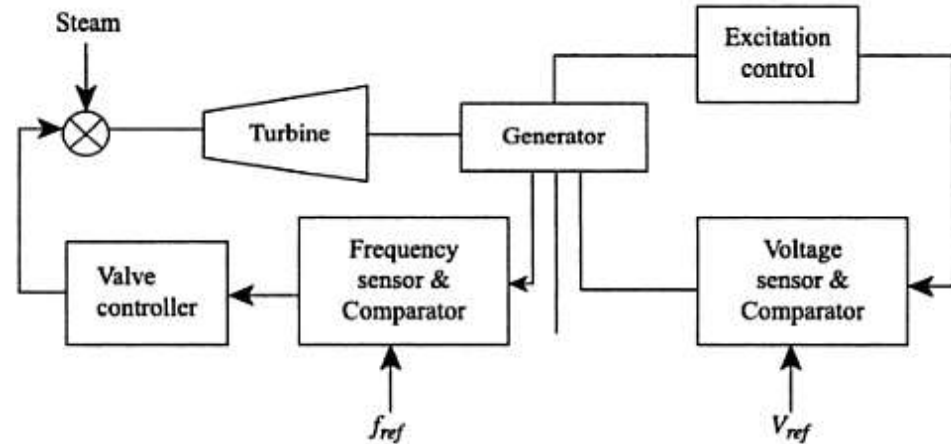

Frequency deviation causes

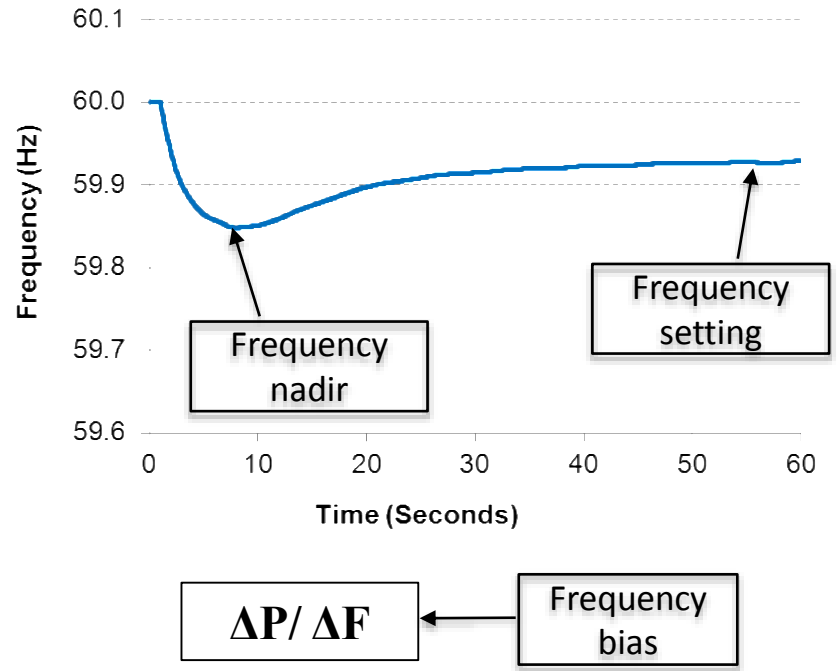
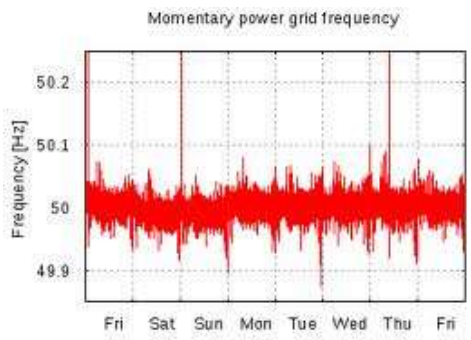
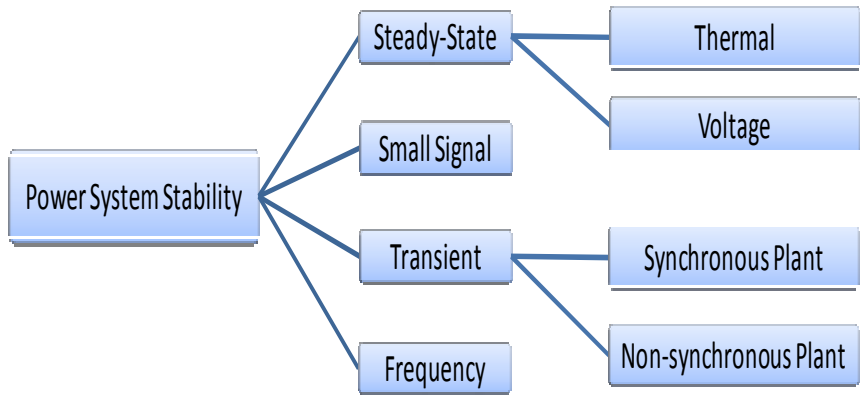

In small systems 2-3MW/ 0.1Hz
 In Large systems 500-600MW/ 0.1HZ

Frequency stability is the ability of the system frequency to stay stable within the safe limits and retunes to its stability after the disturbance is removed.

IEEE1547 Standard for Interconnecting Distributed Resources with Electric Power Systems.

NERC Standard BAL-003, Frequency Response and Frequency Bias.

Frequency deviation impacts

On customer side:
Sensitive electronic devices.

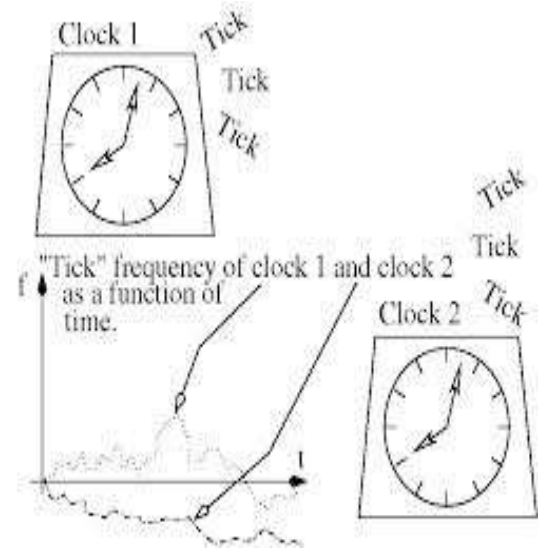

On the grid:

Shed the loads or the generations → Reliability and security of the system.



30-July-2012 and 31-July-2012

Frequency Stability Study for Bornholm Island (2007)

Bornholm is a Danish island

Bornholm → Minimum load **13MW** peak load **63MW**.

AC submarine cable to Sweden **60MW**

Fossil-fueled units **35MW**

Standby units **25MW**

Wind **30MW**

Biogas **2MW**

Voltage levels 60kV, 10kV and 0.4kV



Frequency deviation impacts

CASE STUDIES:

Study conducted on frequency stability impacts:

In 2007 DTU researchers carried out the study.

From 11 to 14 September 2007

-AC cable disconnected → island operation mode

The recorded data was taken every 20ms by PMUs.

Comparison between the frequency deviations of **Nordic grid** and **Bornholm** islanding operation mode with only 6MW wind power (out of 30MW)!

Conclusion → Islanding mode was suffering from several fluctuations in frequency.

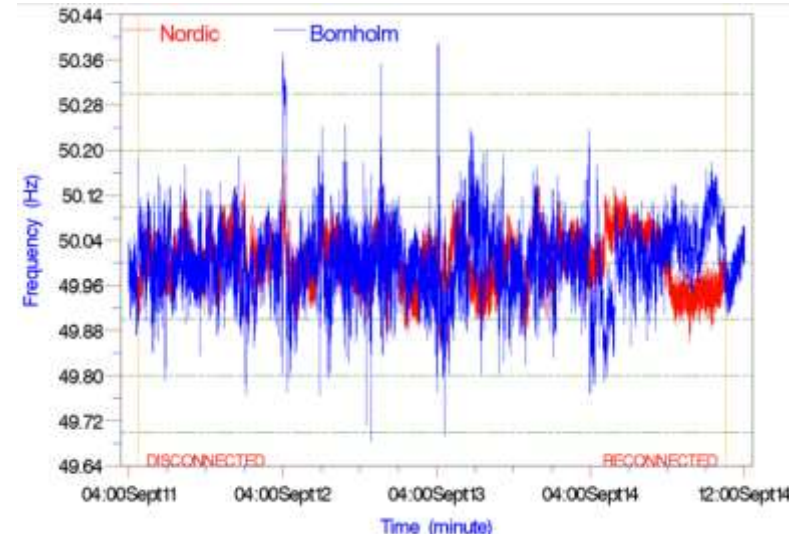

With **6MW** out of **30 MW** of wind power → serious problem of frequency deviation This level of deviation is not allowed in Nordic Grid (2007)

Note: According Nordic Grid regulations the frequency deviation $< 0.1\text{Hz}$ around 50Hz

Frequency Stability Study for Sicily Island (2012)

Sicily is an Italian island in Mediterranean sea.

Sicily' monthly load ranges (2.3GW - 3.7GW)

AC submarine cable to Italy **1GW**

Fossil-fueled units **5.8GW**

Wind **1.68GW**

Hydropower plant **730MW**

PV Solar **864MW**

Biomass **54MW**



Frequency deviation impacts

CASE STUDIES:

Study conducted on frequency deviation after a real incident:

Note: Before 31 May 2012 the over/under frequency trips set to 50.3 and 49.7 Hz for PVs.

The incident:

In 18 May 2011, → system is operating as an islanding mode, AC link was under maintenance. 150 MW generating unit at S. Filippo del Mela power plant → shed down.
frequency decline → 49.7 Hz → PVs of 200 MW is also tripped
frequency decline → 49 Hz. (UFLS) → 180 MW (Frequency restored)

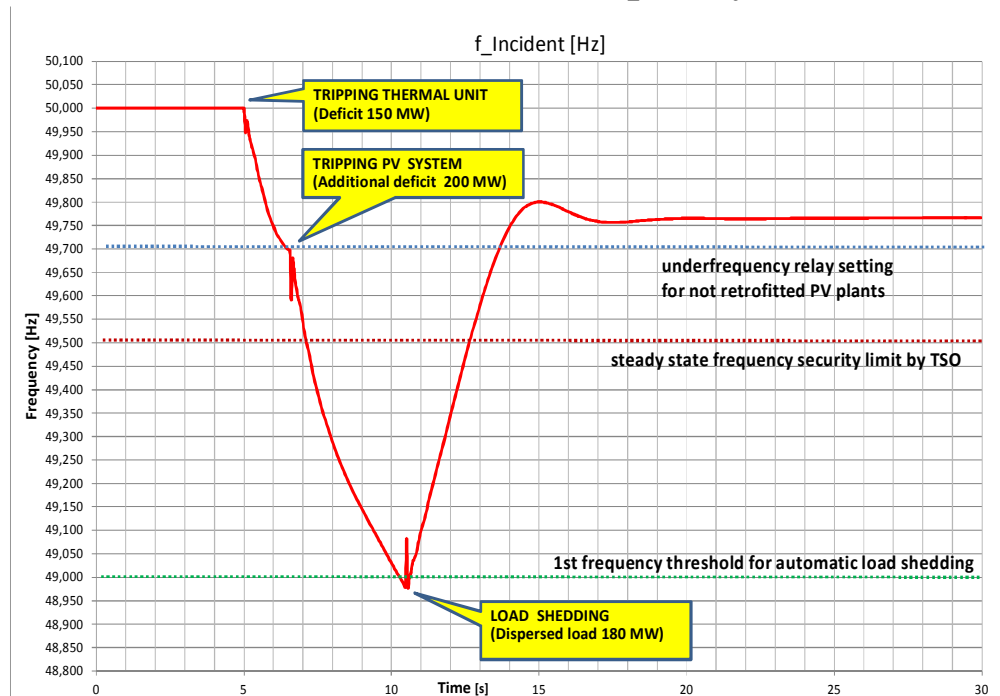

Frequency Stability Study for Hawaii (2010)

Hawaiian Electric Company (HECO) is the main electric utility since 1908 in Hawaii. Subsidiaries Hawaii Electric Light (HELCO) and Maui Electric (MECO).



HELCO → Minimum load **90MW** peak load **191MW**.

Fossil-fueled units fleet including steam, combined-cycle gas, and diesel turbines **200MW**

Geothermal plants **38MW**

Wind **31MW**

Hydropower **17MW**

PV distributed generation **>38MW** + **0.5 MW** CSP plant

Frequency deviation mitigations

The following are the facilities that deal with the roots of frequency deviation to mitigate it.

A. Generation and Load Shedding

Sacrifice the some to Save the all (it's a trade off).

It should be the last choice to maintain the frequency stability.

Because: loss of generations or load → the security and the reliability of the system

B. Keeping Some Inertia

In Denmark, decentralized combined heat plants (DCHP) are located beside the load centers and they are adding inertia to the system.

Hawaii Electric Light HELCO keeps at least two of its three steam units online for all load levels.

Moreover, fast-start gas generators → frequency regulation

Frequency deviation mitigations

C. Modifying AGC's Control Scheme

In case of including variable generations → increase deadband of AGC (Region of no-control) to smooth the frequency response.

Using the droop response of the turbine governor → small frequency variations, AGC → more effective frequency deviations.

These procedures could bring some risk of not response quickly for severe faults.

In 2006 and 2007, two wind installed in Hawaii island.

AGC modified → To overcome the over-control issue in AGC resulting from wind fluctuations. AGC's deadband (no-control region) set to ± 0.2

At excess energy → wind power curtailment is done → less frequency changes



Frequency deviation mitigations

D. Control of Inertial Response in Wind Turbines

Wind turbines a virtual inertia from the rotor shaft. → specific control techniques

GE WindINERTIA controller provides +provides +5% improving in frequency nadir.

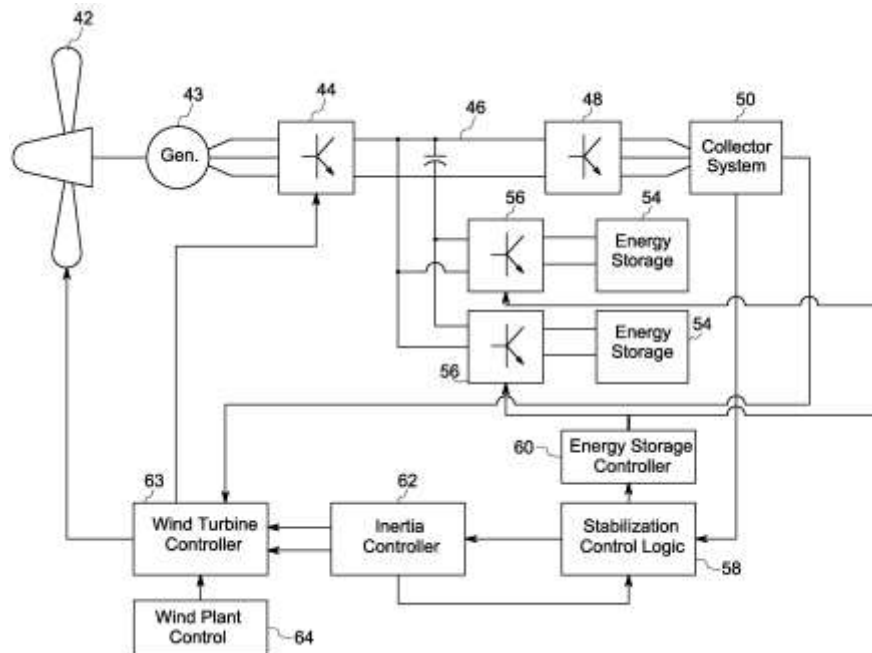

Frequency deviation mitigations

D. Control of Inertial Response in Wind Turbines.

What If ? Scenario

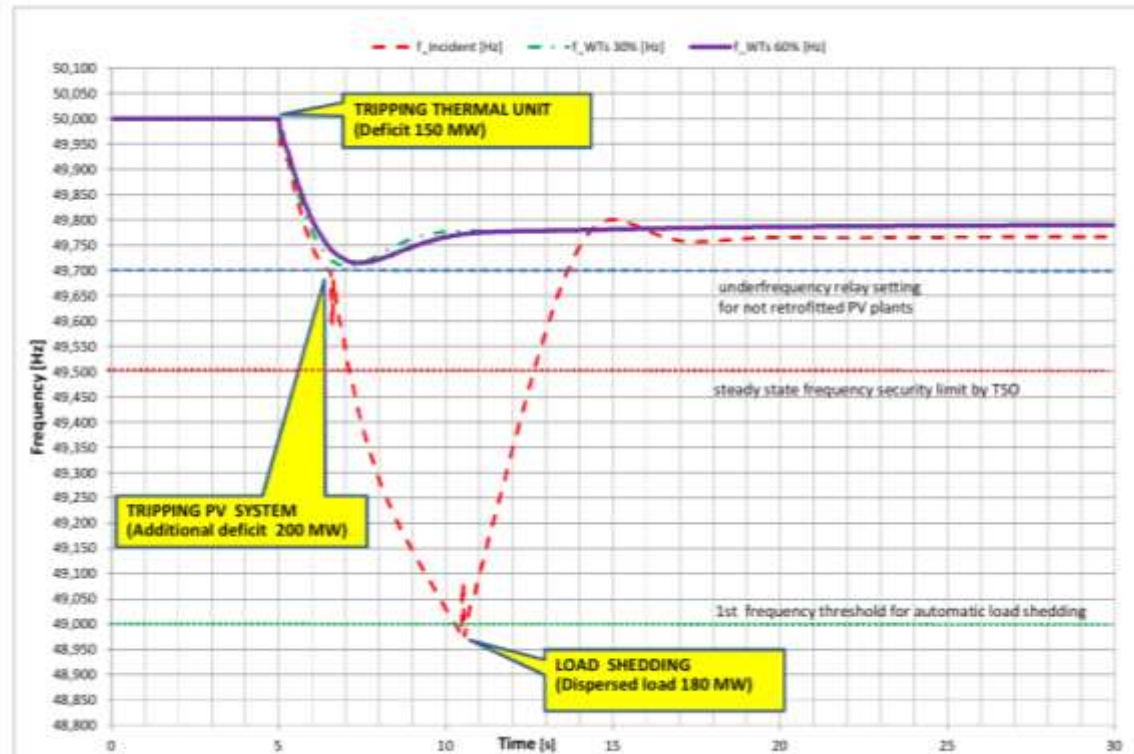

If 30% and 60 % of wind turbines have inertial response in Sicily Island

Frequency deviation mitigations

E. Governor-like Response of Wind Turbines (Wind Power Curtailment)

If the power from wind turbines is harnessed less than the available → wind turbines can be controlled as a governor in thermal unit.

This control scheme of curtailed wind power is effective in frequency response and can arrest the frequency deviation.

This governor-like control can be carried out for large-scale solar plants as well.

But has economic impacts since the power is lost and not recoverable (not like thermal units)

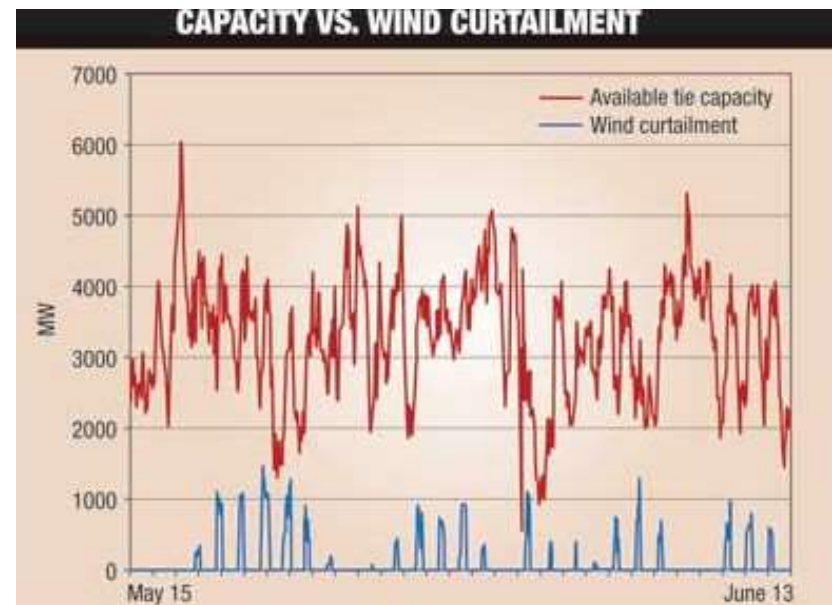

F. Retrofitting the PV Solar Systems

Retrofitting / modifying PV solar systems by just including upgraded the software settings used with inverters and simple new hardware adjustments.

This lead to smooth and flexible disconnect of PV solar systems from the grid.

In 2008 **HELCO** study → Revised IEEE1547.

Under frequency load shed (ULFS) 59 → 58.8Hz.

Trip setting of PVs 59.3 Hz → as close as possible to ULFS (59Hz).



Frequency deviation mitigations

F. Retrofitting the PV Solar Systems

What If ? Scenario

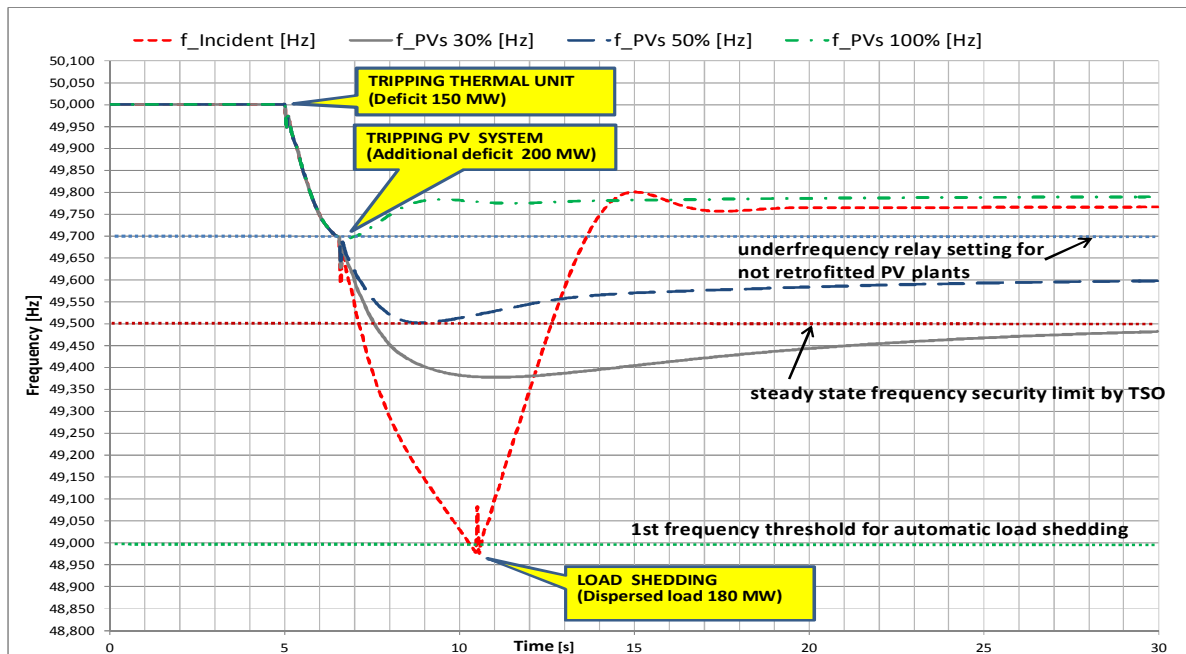

If 30% , 50, and 100 % of PV retrofitting in Sicily Island

Frequency deviation mitigations

G. Energy Storage

Storage systems can provide more flexibility to the system operation and helps for support the frequency stability by decreasing the imbalance.

- Pumping station storage;
- Electric vehicles;
- Nickel-cadmium and Lithium-ion batteries;
- Fuel cells;
- Air-compressed reservoirs;
- Flywheels;
- Superconducting magnetic energy.

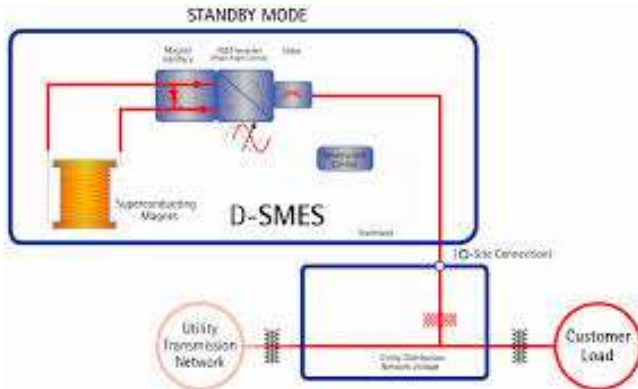
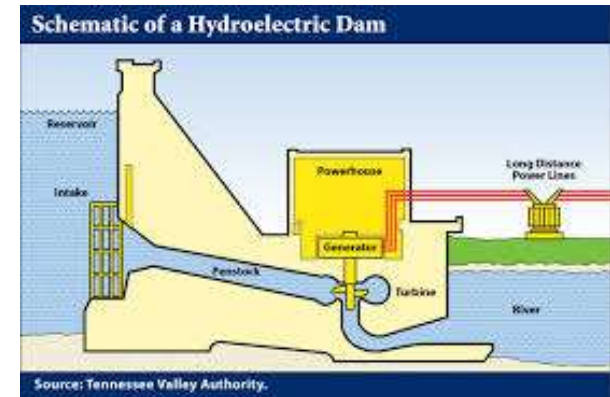

Frequency deviation mitigations

G. Energy Storage

What If ? Scenario

Battery Energy Storage System (BESS)

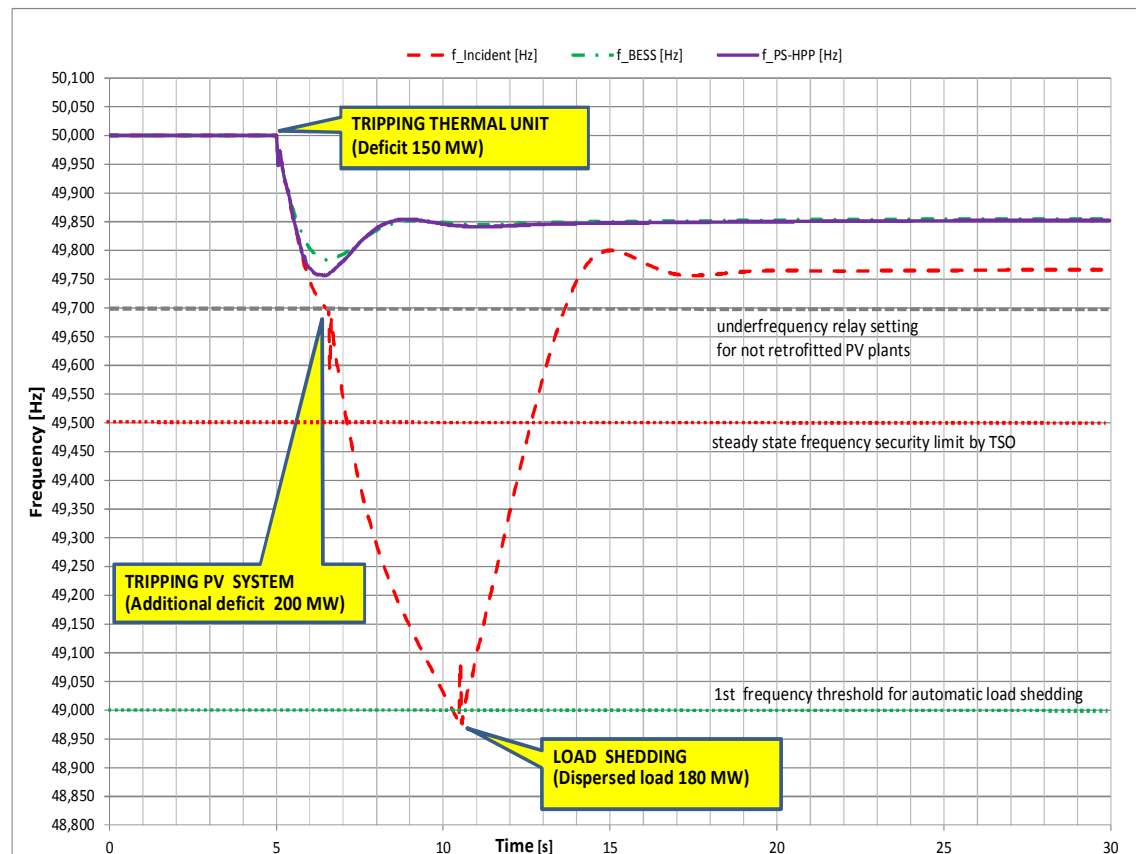

If Pumping station and BESS are used in Sicily Island

Frequency deviation mitigations

H. Demand Response and Energy Efficiency Measures

Significant agricultural loads → Water pumping load tripping
Air conditions, water heaters.

Energy efficiency → the incandescent light → compact fluorescent lights (CFL)

Using variable speed drives

I. HVDC Links

No frequency or synchronization issues involved.

Even with AC links → with larger systems absorb frequency deviations efficiently.

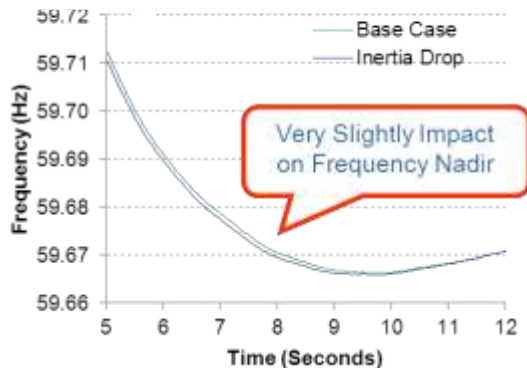

Norway Wants to Be Europe's Battery

A new HVDC line will let Europe store more wind energy in Norway's hydropower system

By Peter Fairley
Posted 21 Oct 2014 | 19:00 GMT

[+](#) Share | [✉](#) Email | [🖨](#) Print



Gotland Island
HVDC link 1954

Frequency deviation mitigations

J. Power System Stabilizer (PSS)

Reduce the oscillation in poorly damped inter-area.

And with fast response of governor-like wind turbines oscillation.

K. Electronic Shock Absorber (ESA)

ESA is a device invented by Hawaiian electric company to smooth frequency from short-term wind power variations. Its mechanism is as a shock absorber

Storing the excess energy during the period of surplus generation of wind power and release it in the period of deficit wind power generation.

[HOME](#) > [OVERHEAD DISTRIBUTION](#) > ELECTRONIC SHOCK ABSORBER GIVES HAWAIIAN WIND FARM A BOOST

Electronic Shock Absorber Gives Hawaiian Wind Farm a Boost

| *T&D World Magazine*

Sep 1, 2006

Frequency deviation mitigations

L. Variable Generation Forecasting

Helps of keeping the power balance of the system and mitigate the problem of frequency stability.



M. Electricity Market Structure

Restructure the market for the frequency response.

Bids and offers between the participants at regulation marketing periods.

Incentives for energy storage and demand response schemes.

Such strategies can be allowing more flexibility in balancing the power and hence improving the frequency stability.



Conclusions

- The frequency deviation is taking more attention since many electrical systems work at its frequency boundary.
- In the small isolated systems such as island systems the frequency stability becomes more a considerable issue.
- Especially, when the renewable resources are taking a large share of the generation in these systems.
- The mitigation facilities sometimes are not affordable or have an economic impacts
- There is a need for updating the policy to accommodate the modern structure of electrical systems.
- Advancement in frequency stability studies should take place and continue to develop affordable solutions to improve the frequency stability.

References

- [1] Y. Chen, Zhao Xu, and J. Østergaard, "Frequency analysis for planned islanding operation in the Danish distribution system-Bornholm," *Univ. Power Eng. ...*, pp. 9–13, 2008.
- [2] A. J. Conejo, J. M. Morales, J. A. Martínez, and A. Motivation, "Tools for the Analysis and Design of Distributed Resources — Part III : Market Studies," vol. 26, no. 3, pp. 1663–1670, 2011.
- [3] E. Reliability and P. I. Plan, "Lessons Learned : Planning and Operating Power Systems with Large Amounts of Renewable Energy-Based Power Generation," no. August, 2012.
- [4] Z. Hussain, Z. Chen, and P. Thøgersen, "Challenges of Danish Power System and their possible solutions," *proc. IEEE Conf. POWERCON*, 2012.
- [5] "HELCO Facts." [Online]. Available: <http://www.hawaiielectriclight.com/helco/About-Us/Company-Facts>.
- [6] L. C. Dangelmaier, "System frequency performance of the Hawaii Electric Light System," *2011 IEEE Power Energy Soc. Gen. Meet.*, pp. 1–8, Jul.2011.
- [7] E. Ciapessoni and D. Cirio, "Renewable power integration in Sicily: Frequency stability issues and possible countermeasures," in *IREP Symposium-Bulk Power System Dynamics and Control*, 2013.
- [8] N. W. Miller, "California ISO Frequency Response Study," no. November, 2011.
- [9] ECOFYS, "Impact of Large-scale Distributed Generation on Network Stability," 2011.
- [10] B. P. Fairley, "Norway Wants to Be Europe ' s Battery A new HVDC line will let Europe store more wind energy in Norway ' s hydropower system," pp. 4–5, 2014.
- [11] IEC, "Grid integration of large-capacity Renewable Energy sources and use of large-capacity Electrical Energy Storage," 2012.
- [12] M. Matsuura, "Island Breezes," *IEEE Power Energy Mag.*, no. December, pp. 59–64, 2009.
- [13] J. Horne, D. Flynn, and T. Littler, "Frequency stability issues for islanded power systems," *IEEE PES Power Syst. Conf. Expo. 2004.*, pp. 188–195.
- [14] "Hawaiian Electric exec receives patent on device to stabilize wind energy," 2004. [Online]. Available: [http:// www.elp.com/articles/2004/07/hawaiian-electric-exec-receives-patent-on-device-to-stabilize-wind-energy-on-small-or-remote-grids.html](http://www.elp.com/articles/2004/07/hawaiian-electric-exec-receives-patent-on-device-to-stabilize-wind-energy-on-small-or-remote-grids.html).

Thank you for listening

Any Question ?